

# HIGHWAY LANDSCAPE DEVELOPMENT PROJECT

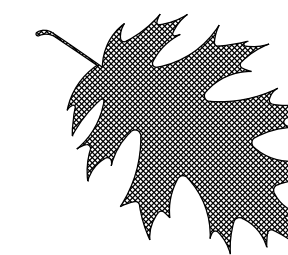

I-85 & NC 109 IN THOMASVILLE

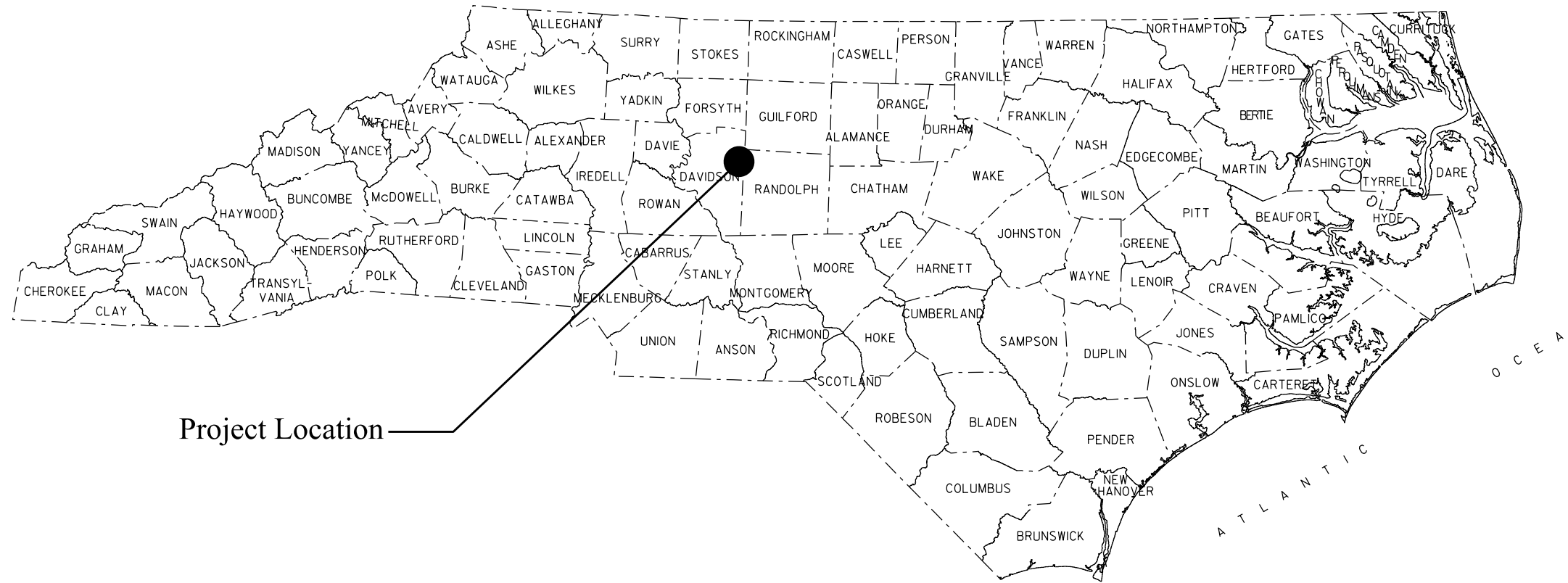
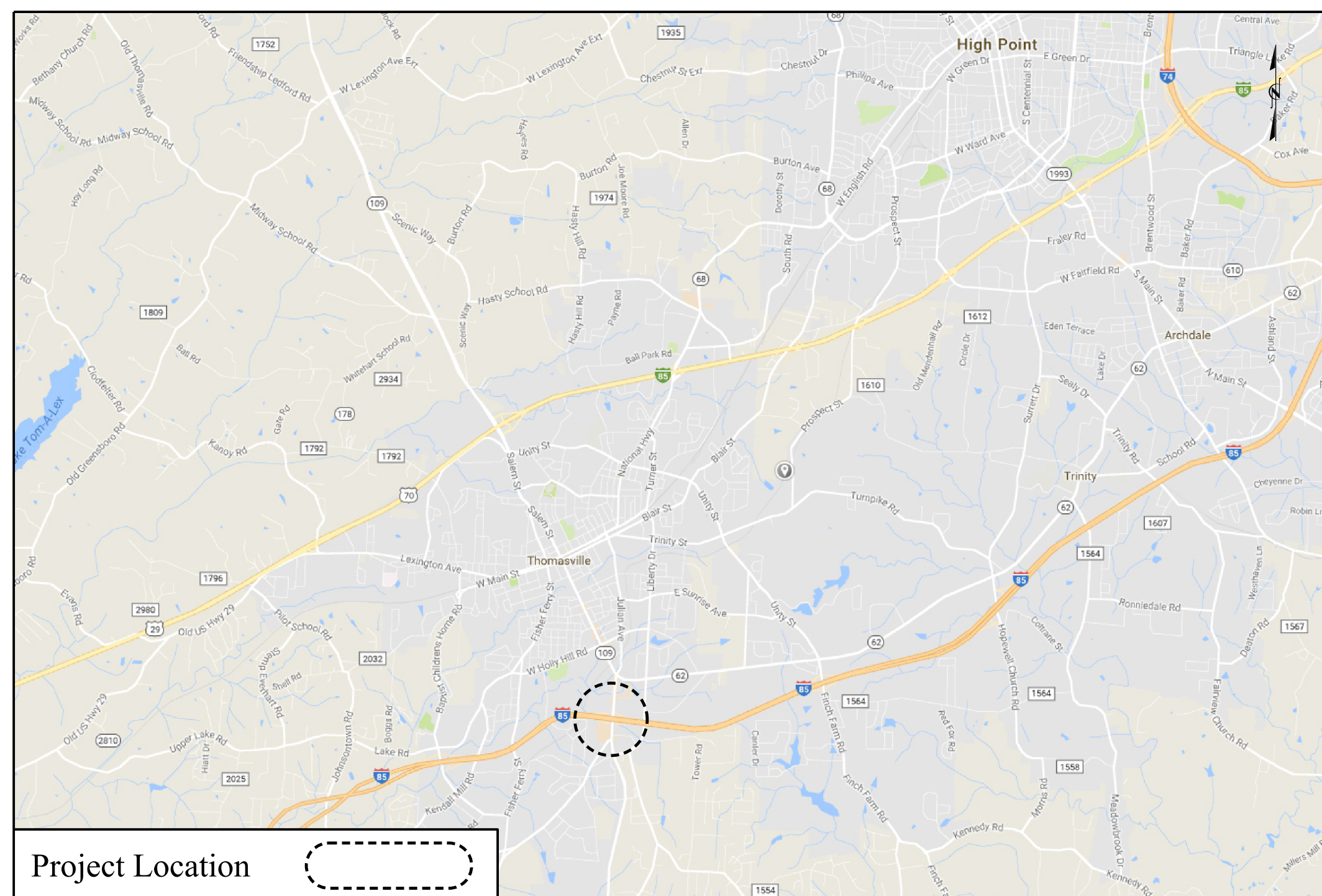

Project Location

T.I.P. #	STATE PROJECT W.B.S. #	SHEET #	SHEET # TOTAL
---	---	L1	10
FED. PROJ. #	DESCRIPTION		DIVISION
---	Enhancement		9

### CONVENTIONAL SYMBOLS

County Line	-----
City or Town Line	-----
Exist. Right of Way Line Marker	-----▲-----
Prop. Right of Way Line Marker (By Others)	-----▲-----
Prop Right of Way Line Marker (By Contract)	-----▲-----
Exist. Control of Access Line	-----○-----
Prop. Control of Access Line	-----○-----
Property Line	-----
Easement Line	-----
Slope Stake Line	-----
Exist. Fence	-----
Prop. Woven Wire Fence	-----
Prop. Chain Link Fence	-----
Exist. Road	-----
Prop. Road	-----
Guardrail	-----
Survey Line	-----
Denotes Line Equality	-----
Bridge	-----
Culvert	-----
Railroad	-----
Woods	-----
Exist. Telephone Pole	-----
Prop. Telephone Pole	-----
Tower Pole and Line	-----
Exist. Power Pole	-----
Prop. Power Pole	-----
Sanitary Sewer Line	-----
Water Line	-----
Gas Line	-----
Picnic Shelter	-----
Regeneration	-----
Reforestation	-----

### Summary of Quantities 1 Year Establishment

DES	SEC	QTY	UNIT	KEY	BOTANICAL NAME	COMMON NAME	SIZE	CALIPER	FURNISH	A.S.N.S.	REMARKS
<b>Trees</b>											
L	1670	17	ea	CO	<i>Cercis canadensis</i> var. <i>texensis</i> 'Oklahoma'	Oklahoma Redbud		1.5-2"	B&B	2.3	18' O.C.
L	1670	12	ea	JB	<i>Juniperus virginiana</i> 'Burkii'	Burkii Eastern Red Cedar	7-8"		B&B	4.7	12' O.C.
L	1670	16	ea	MB	<i>Magnolia grandiflora</i> 'Bracken's Brown Beauty'	Bracken's Brown Beauty Magnolia	7-8"		B&B	2.2	As Shown
L	1670	18	ea	MP	<i>Morus</i> x 'Prairifire'	Prairifire Crabapple		1.5-2"	B&B	2.4	40' O.C.
<b>Shrubs</b>											
L	1670	78	ea	DV	<i>Distylium</i> 'Vintage Jade'	Vintage Jade Distylium	15-18"		#3 Cont.	5.4	4' O.C., Staggered
L	1670	67	ea	FI	<i>Forsythia</i> x <i>intermedia</i> 'Mindor'	Showoff® Forsythia	18-24"		#3 Cont.	3.3	6' O.C.
<b>Grasses/Groundcovers/Perennials/Bulbs</b>											
L	1670	2559	ea	HO	<i>Hemerocallis</i> 'Orange Veld' ['Tusawilla Tigress', 'Orange']	Orange Veld Daylily ['Tusawilla Tigress', 'Orange']	6-12"		#1 Cont.	13.2,3	2' O.C.
L	1670	270	ea	PN	<i>Panicum virgatum</i> 'Northwind'	Northwind Switchgrass	6-12"		#1 Cont.	13.4	3' O.C.
L	1670	544	ea	RF	<i>Rudbeckia fulgida</i> var. <i>sulfurata</i> 'Goldsturm'	Goldsturm Black-Eyed Susan	6-12"		#1 Cont.	13.3	2' O.C.
L	1670	114	ea	TW	<i>Tulipa</i> 'Purissima' ['Maureen']	Purissima Tulip ['Maureen']	Bulb		Pack of 50	12.22	2 bulbs per sqft
L	1670	117	ea	TP	<i>Tulipa</i> 'Purple Prince' ['Negrita']	Purple Prince Tulip ['Negrita']	Bulb		Pack of 50	12.22	2 bulbs per sqft
<b>Other Vegetation Costs</b>											
L	SP	0.15	acre		Bulb Naturalization						
L	1670	9149	sq		Existing Plant Bed Removal						
L	1670	13	ea		Selective Tree Removal, 6"						
L	1670	17	ea		Selective Tree Removal, 10"						
L	1670	4	acre		Selective Vegetation Removal/ Pruning						
L	1670	386	cy		Mulch						Depth of 4"
L	1670	69	mg		Water for Planting						
L	1670	1.6	acre		Seeding & Mulching (Fescue)						
L	1670	15000	sq		Pre & Post Emergence Herbicidal Treatment						
L	SP	460	LF		Spaced Wood Fence						
L	1670	12	ea		Monthly Maintenance						
L	1101	1	LS		Traffic Control						

[ ] - Alternative Plant Option

### INDEX OF L SHEETS:

- L 1.0 - Title Sheet
- L 2.0 - Plant & Fence Details
- L 3.0 - Demolition Plan
- L 4.0 - Planting Plan Quadrant Key
- L 5.0 - Planting Plan Quadrant A
- L 6.0 - Bulb Layout Plan Quadrant A
- L 7.0 - Planting Plan Quadrant B
- L 8.0 - Planting Plan Quadrant C
- L 9.0 - Planting Plan Quadrant D
- L 10.0 - Bulb Layout Plan Quadrant D

PREPARED BY: KC DATE: 11/2017

### REVISIONS

DATE	DESCRIPTION

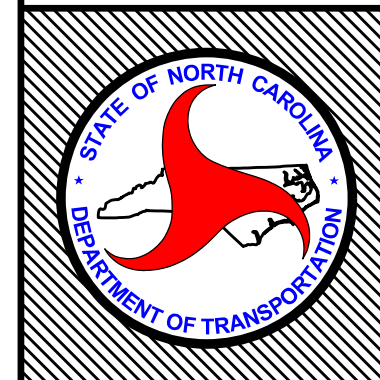

STATE OF  
NORTH CAROLINA  
DEPARTMENT OF TRANSPORTATION

LOCATION: I-85 & NC 109 in Thomasville

TYPE of WORK: Enhancement

COUNTY: Davidson County

2014 American Standard for Nursery Stock  
2018 NCDOT STANDARD SPECIFICATIONS  
PREPARED IN THE OFFICE OF:  
NCDOT- ROADSIDE ENVIRONMENTAL UNIT  
LANDSCAPE DESIGN & DEVELOPMENT SECTION  
1557 MAIL SERVICE CENTER  
RALEIGH NC 27699 919-707-2920

- NOTES:**
- SCHEDULE FOR PLANT HOLE SIZE: PLANT HOLE WIDTH (X) TO BE TWICE THE ROOT BALL SIZE OR CONTAINER DIAMETER.
  - SEE STANDARD SPECIFICATIONS FOR PLANT BED FUMIGATION AND HERBICIDAL TREATMENT.
  - APPLY FERTILIZER AT PLANTING TIME IN THE FORM OF A SLOW RELEASE PELLET OR TABLET. APPLY AT RATE RECOMMENDED BY MANUFACTURER. BOTH RATE AND FORMULATION MUST BE APPROVED BY FIELD ENGINEER PRIOR TO APPLICATION.
  - REMOVE WIRE BASKET AND FOLD BURLAP BACK FROM TOP OF ROOT BALL BEFORE BACKFILLING IS COMPLETE.
  - ALL PRUNING TO FOLLOW STANDARD ARBORICULTURAL PRACTICES AS SPECIFIED BY INTERNATIONAL SOCIETY OF ARBORICULTURE.
  - DO NOT ATTEMPT TO STRAIGHTEN A TREE THAT HAS BEEN PLANTED AT AN ANGLE WITH THE USE OF STAKING OR GUYING. DIG TREE AND REPLANT TO UPRIGHT POSITION.

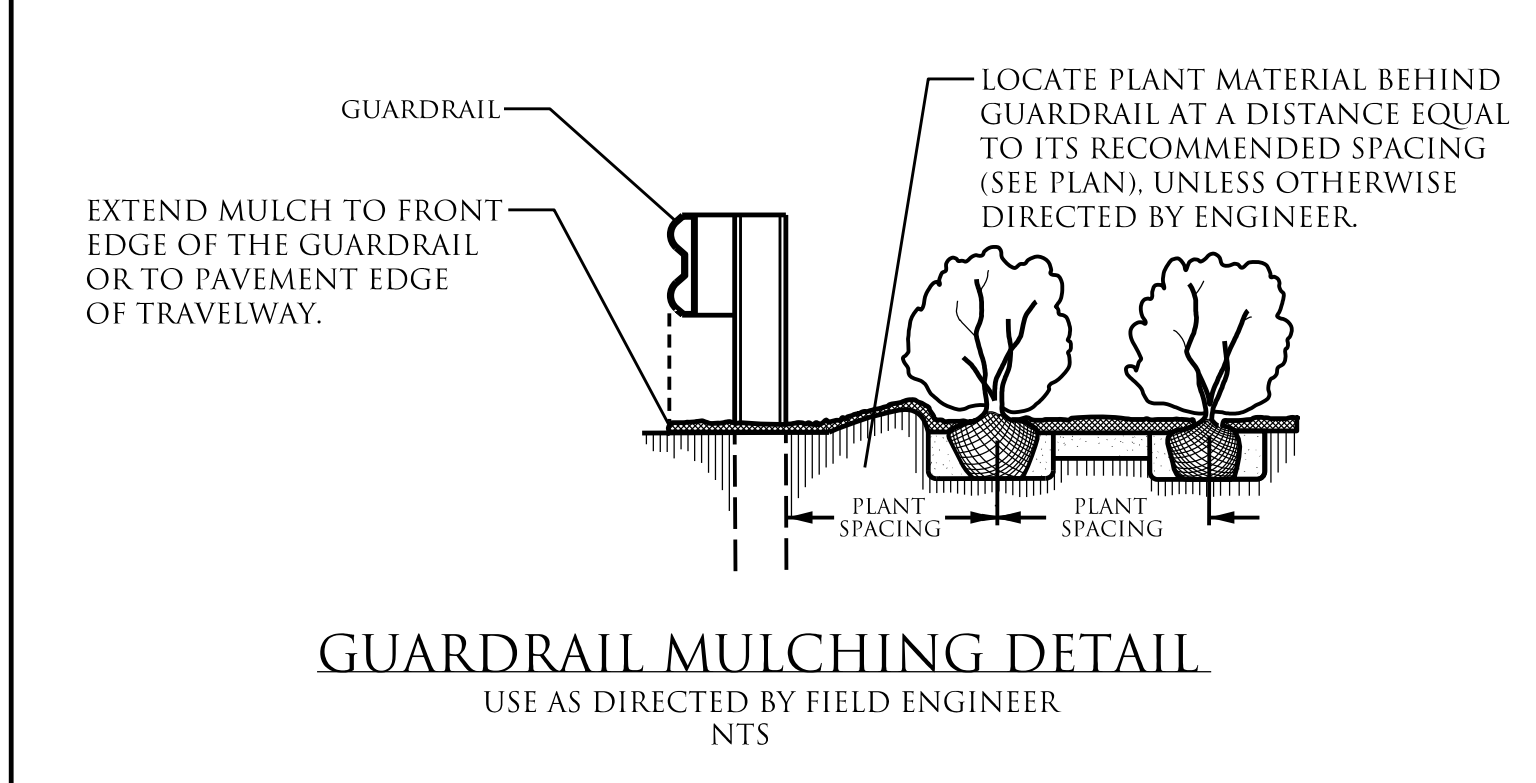
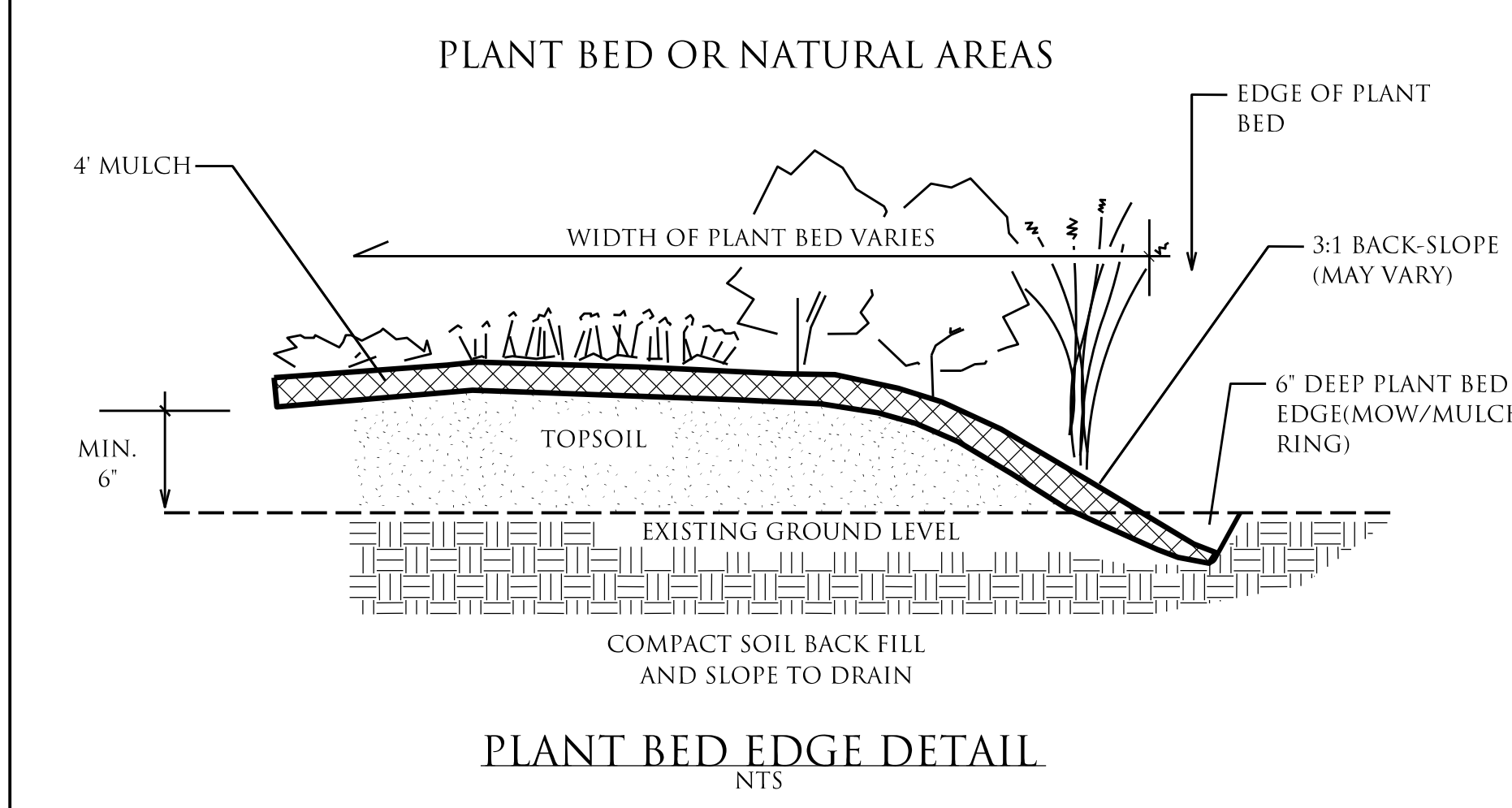
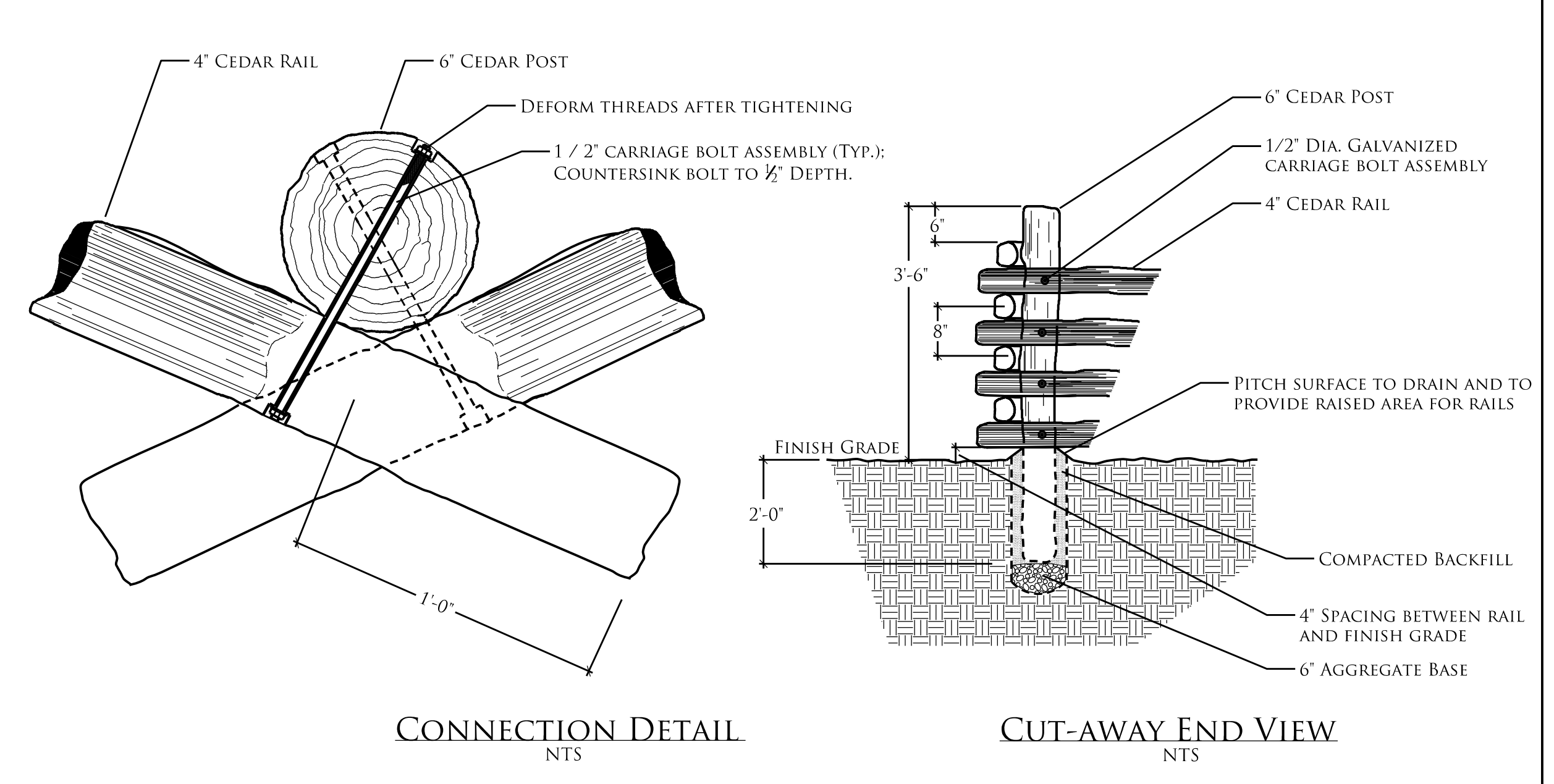
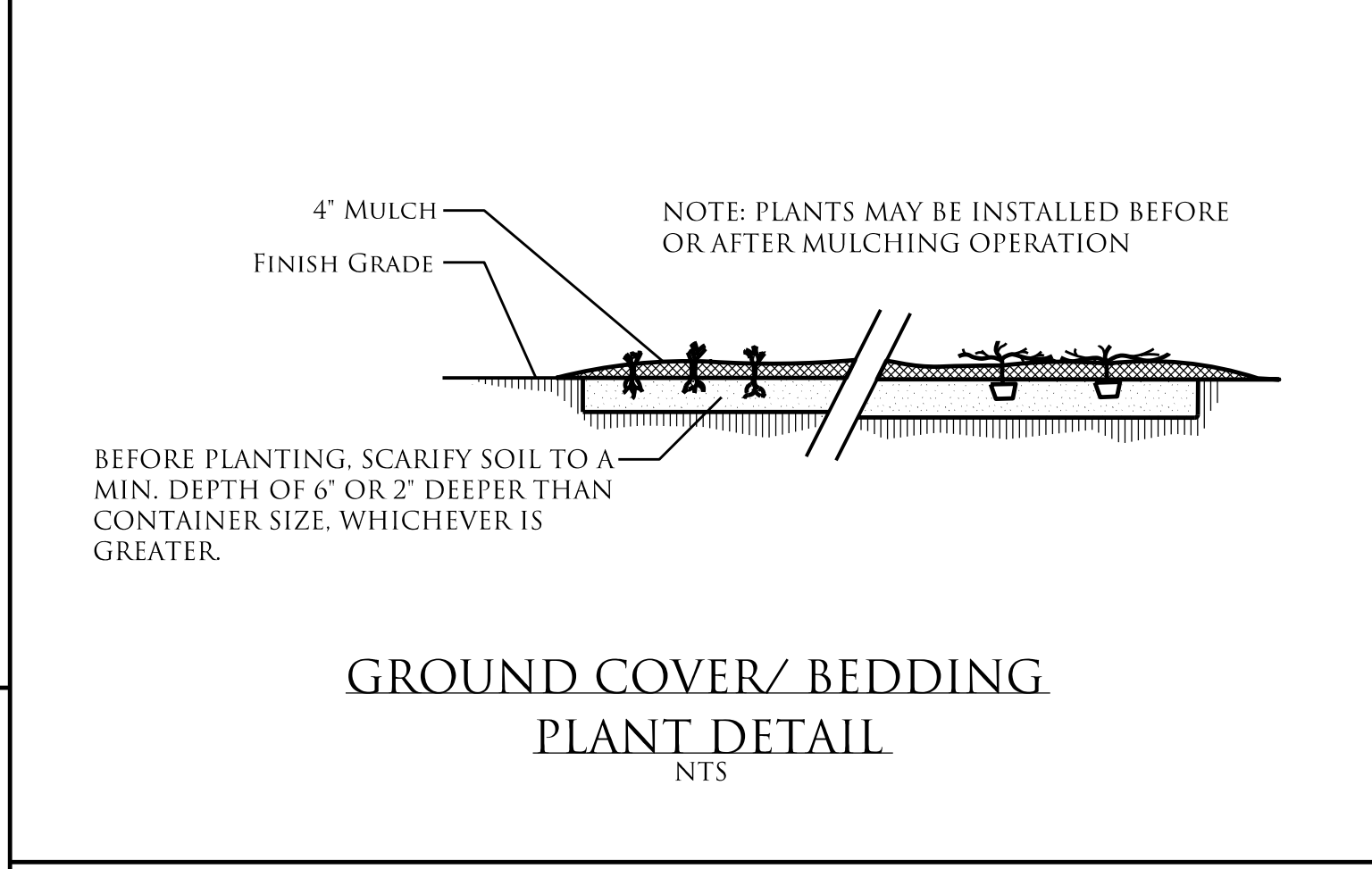
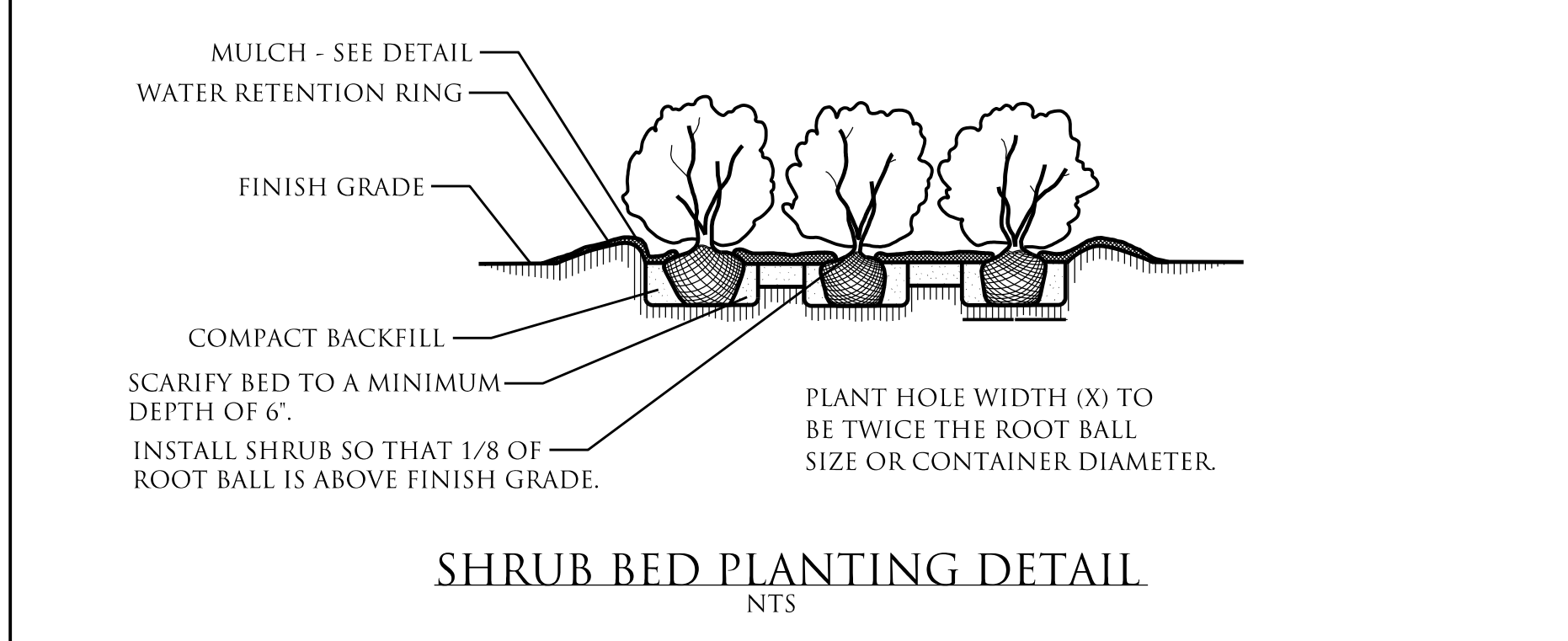
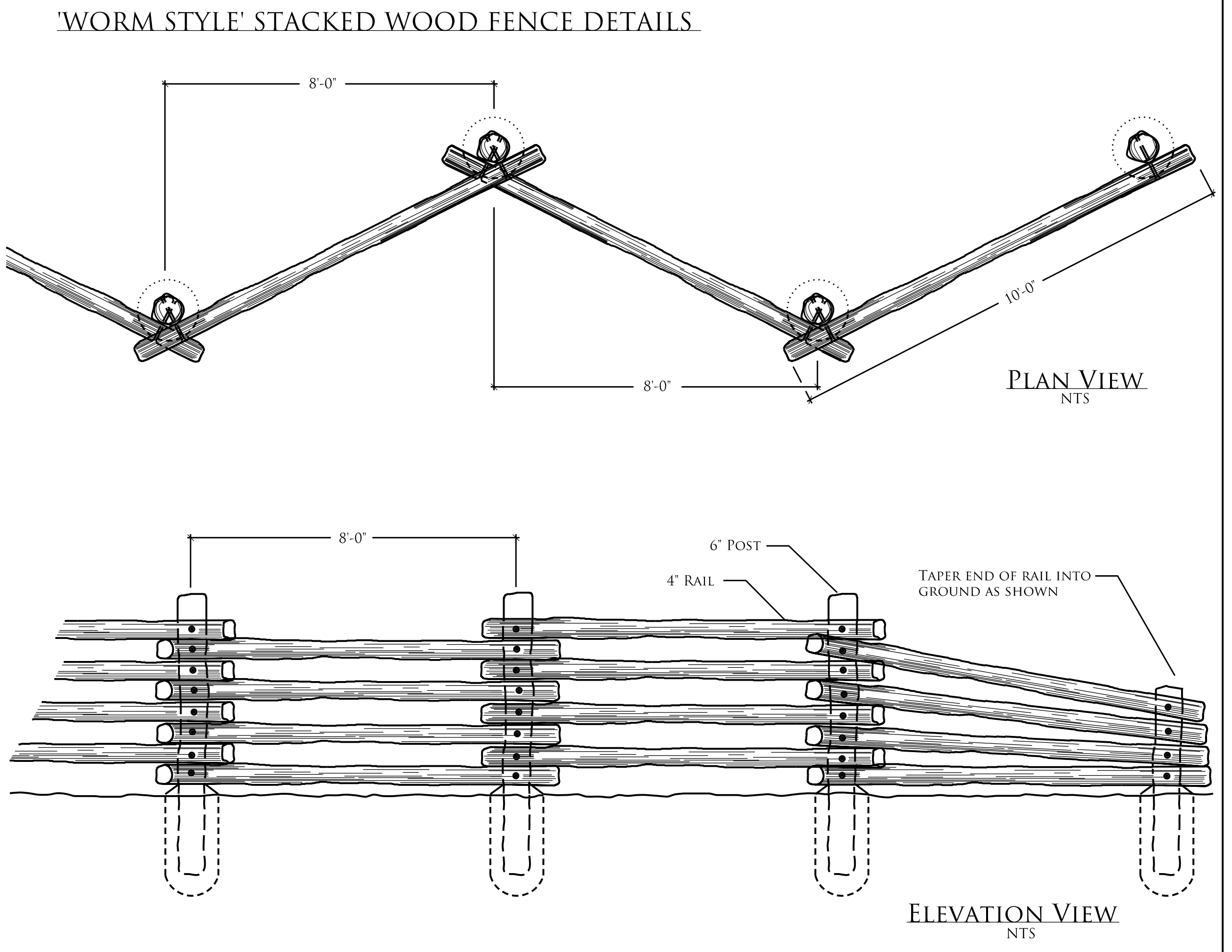
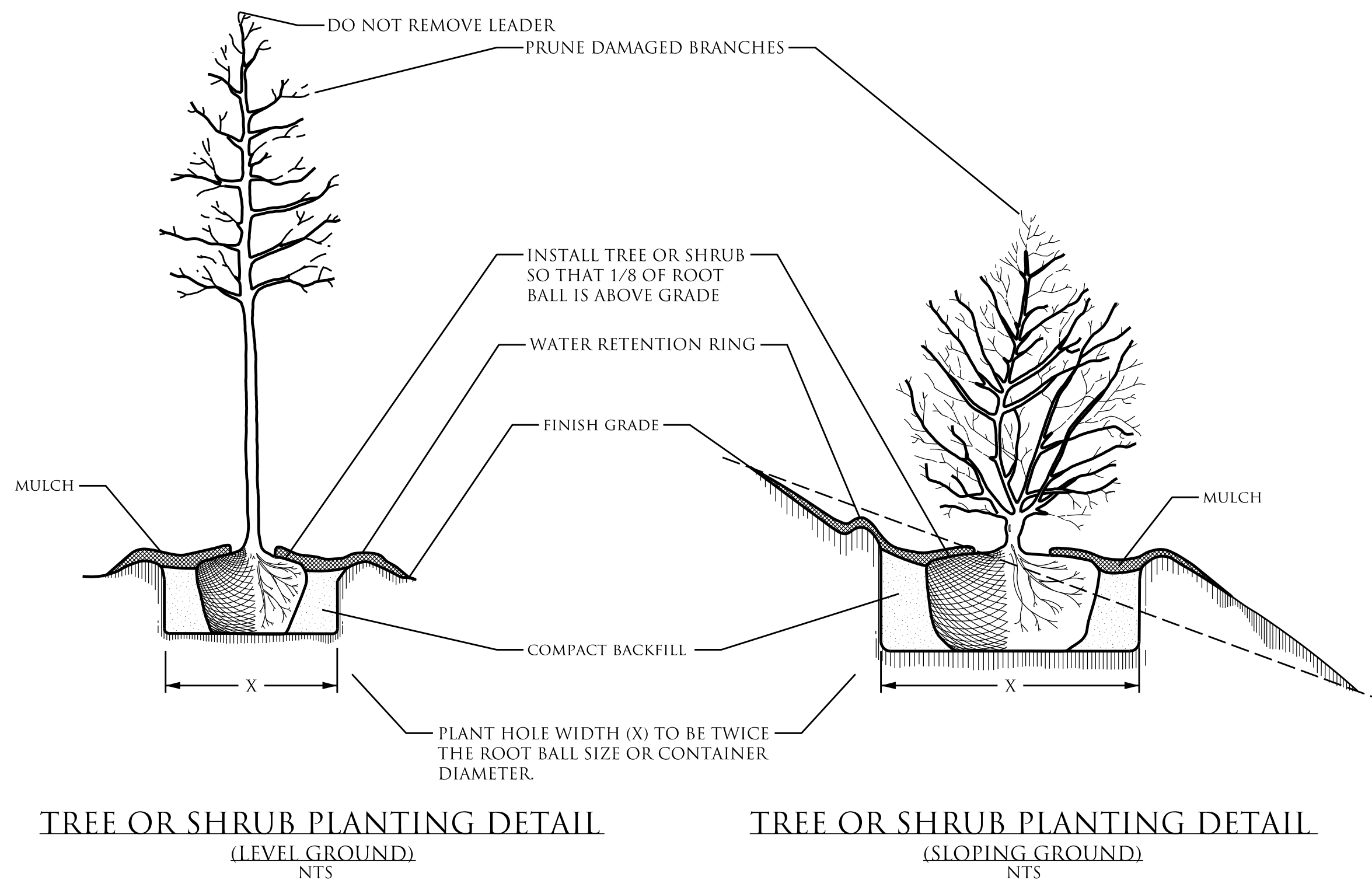

NCDOT - ROADSIDE ENVIRONMENTAL UNIT  
 LANDSCAPE DESIGN & DEVELOPMENT  
 1557 MAIL SERVICE CENTER RALEIGH NC 27699-1557  
 PH: 919-707-2935 FAX: 919-715-2554  
[HTTP://WWW.NCDOT.ORG/DOH/OPERATIONS/DP\\_CHIEF\\_ENG/ROADSIDE/](http://www.ncdot.org/DOH/OPERATIONS/DP_CHIEF_ENG/ROADSIDE/)

I-85 & NC 109 IN THOMASVILLE  
 DAVIDSON COUNTY  
 WBS #: - - - - -

REV. DESIGNER  
 Kyle Coady

PREL. DESIGN DATE:	NOV. 1, 2017
CHECKED BY & DATE:	- - - - -
FINAL DESIGN DATE:	- - - - -

PLANT & FENCE DETAILS  
 LANDSCAPE PLAN SHEET

T.I.P. #	- - - - -
WBS #	- - - - -
FED I.D. #	- - - - -
SHEET NO.:	L-2
TOTAL SHEET NO.:	L-10

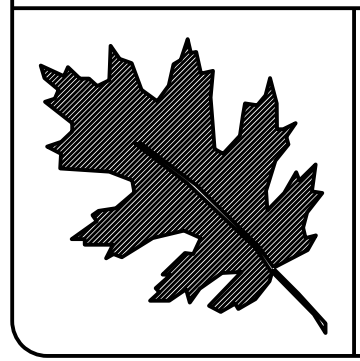
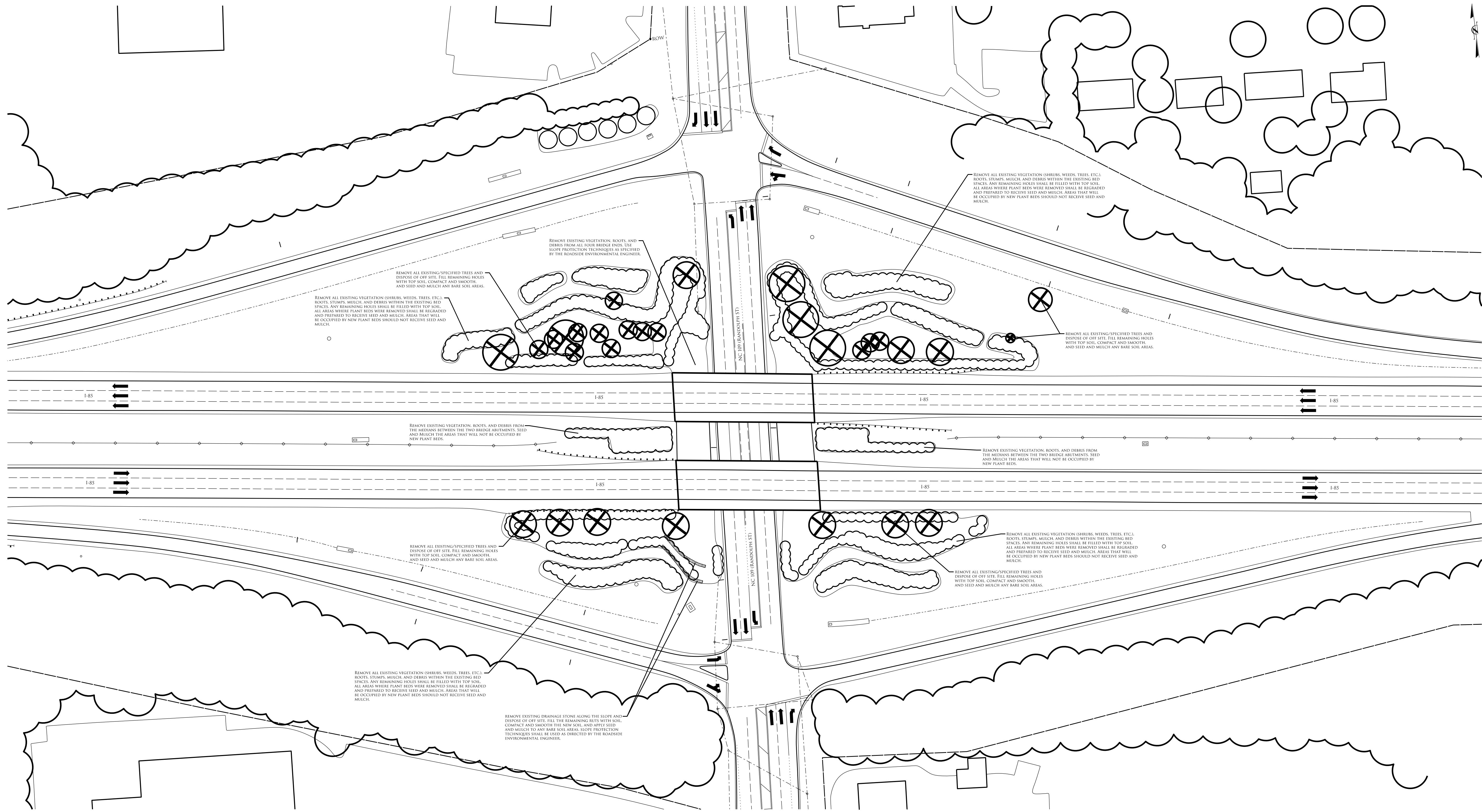

NCDOT - ROADSIDE ENVIRONMENTAL UNIT  
 LANDSCAPE DESIGN & DEVELOPMENT  
 1557 MAIL SERVICE CENTER RALEIGH NC 27699-1557  
 PH: 919-707-2935 FAX: 919-715-2554  
[HTTP://WWW.NCDOT.ORG/DOH/OPERATIONS/DP\\_CHIEF\\_ENG/ROADSIDE/](http://www.ncdot.org/DOH/OPERATIONS/DP_CHIEF_ENG/ROADSIDE/)

I-85 & NC 109 IN THOMASVILLE  
 DAVIDSON COUNTY  
 WBS #: - - - - -

REV. DESIGNER  
*Kyle Corder*

SHEET DESCRIPTION:	PREL. DESIGN DATE:	NOV. 1, 2017
	CHECKED BY & DATE:	- - - - -
	FINAL DESIGN DATE:	- - - - -

DEMOLITION PLAN  
 LANDSCAPE PLAN SHEET

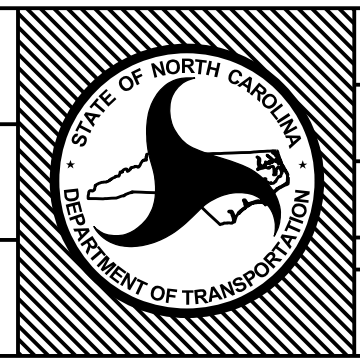

T.I.P. #	- - - - -
WBS #	- - - - -
FED I.D. #	- - - - -
SHEET NO.:	<b>L-3</b>
TOTAL SHEET NO.:	<b>L-10</b>

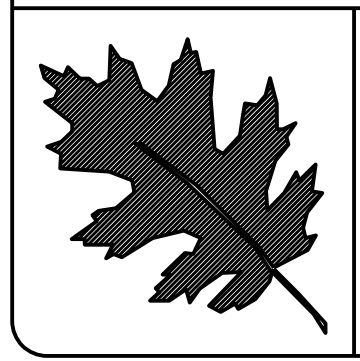
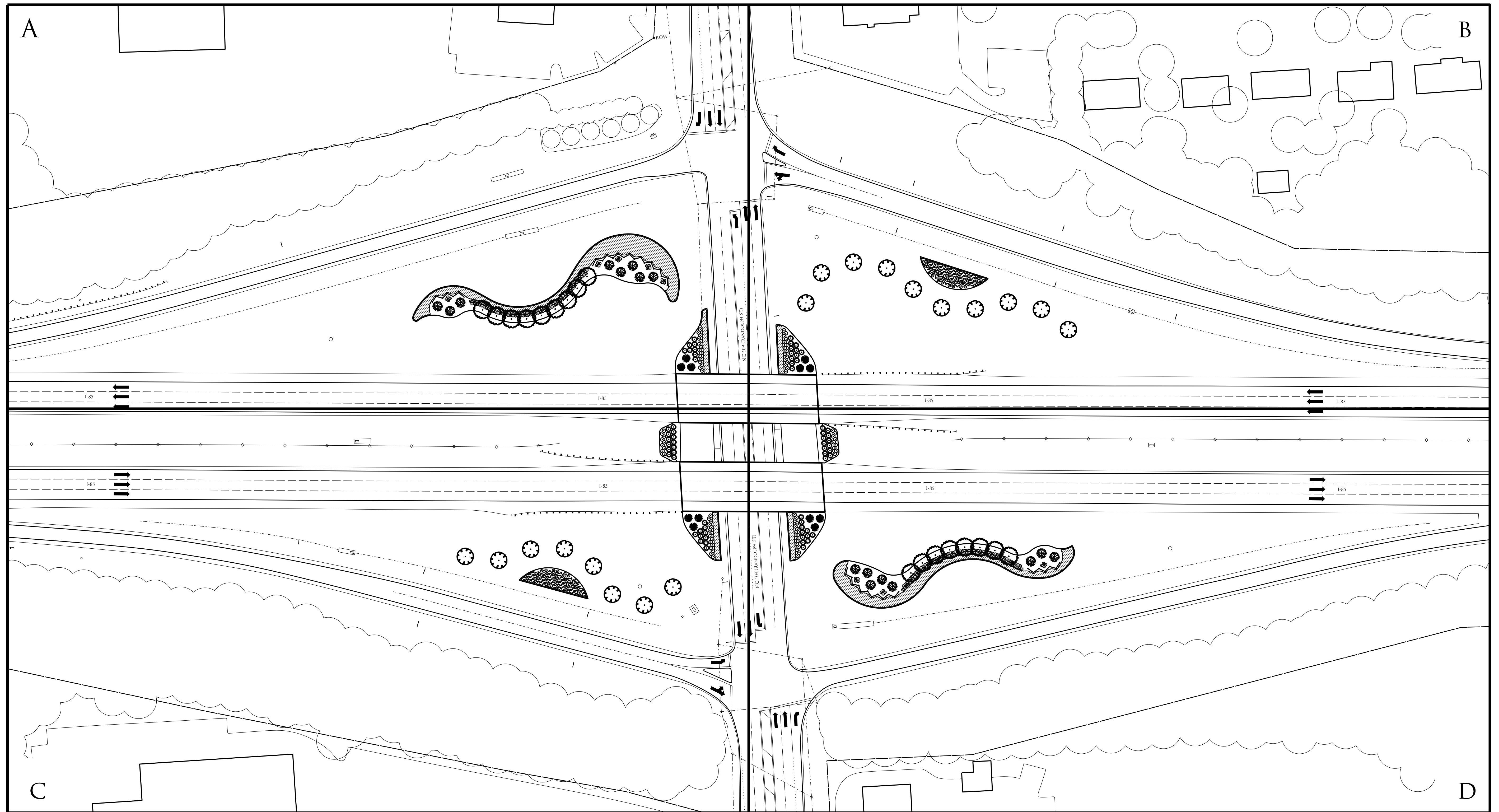

NCDOT - ROADSIDE ENVIRONMENTAL UNIT  
 LANDSCAPE DESIGN & DEVELOPMENT  
 1557 MAIL SERVICE CENTER RALEIGH NC 27699-1557  
 PH: 919-707-2935 FAX: 919-715-2554  
[HTTP://WWW.NCDOT.ORG/DOH/OPERATIONS/DP\\_CHIEF\\_ENG/ROADSIDE/](http://www.ncdot.org/DOH/OPERATIONS/DP_CHIEF_ENG/ROADSIDE/)

I-85 & NC 109 IN THOMASVILLE  
 DAVIDSON COUNTY  
 WBS #: - - - - -

REV. DESIGNER  
*Kyle Corder*

SHEET DESCRIPTION:  
 PREL. DESIGN DATE: NOV. 1, 2017  
 CHECKED BY & DATE: - - - - -  
 FINAL DESIGN DATE: - - - - -

QUADRANT KEY  
 LANDSCAPE PLAN SHEET

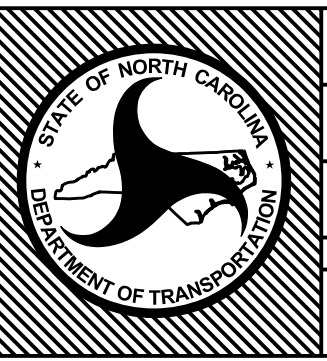

T.I.P. # - - - - -  
 WBS # - - - - -  
 FED I.D. # - - - - -  
 SHEET NO.: **L-4** TOTAL SHEET NO.: **L-10**

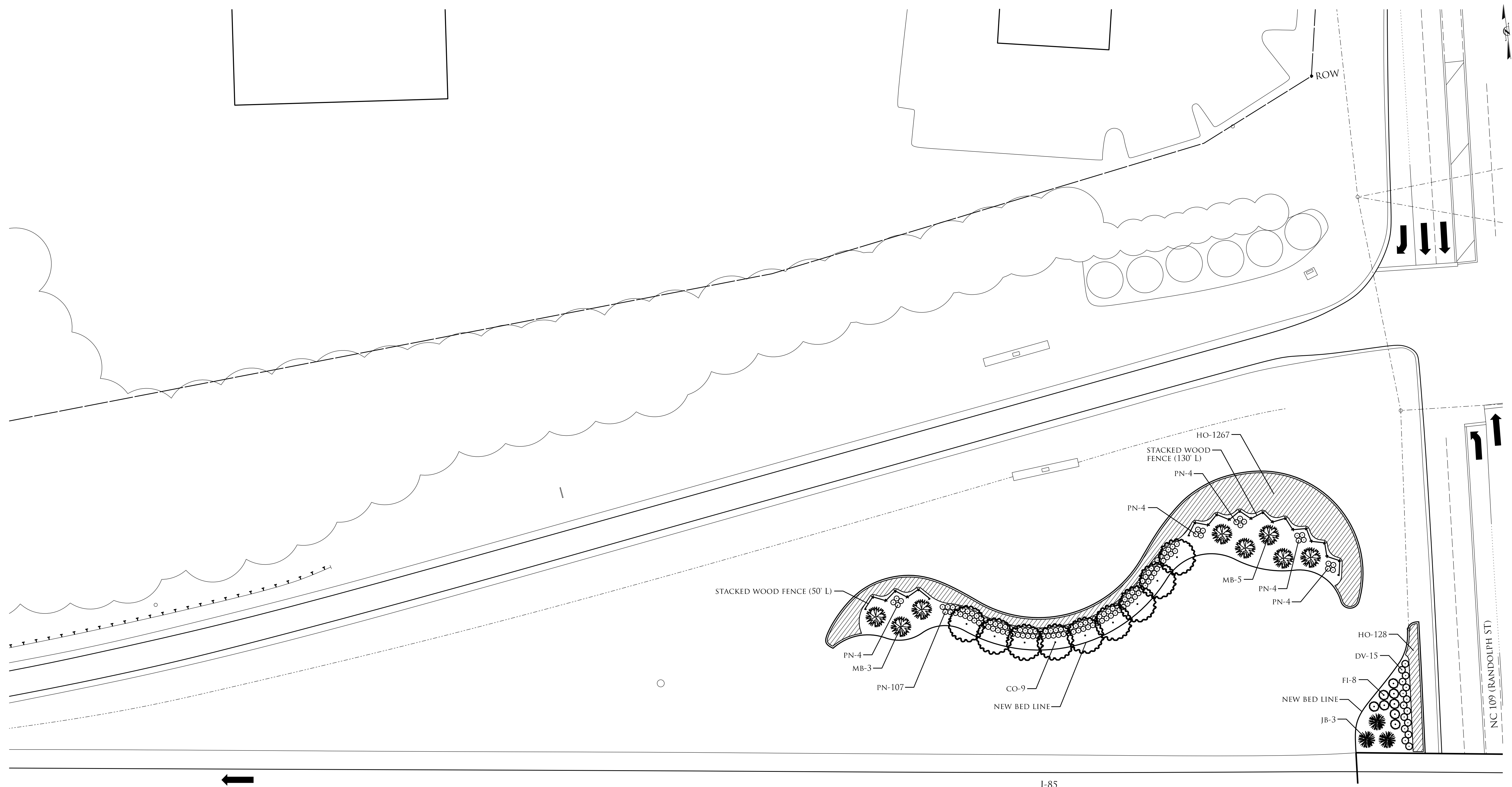

I-85

I-85

NC 109 (RANDOLPH ST)



QTY	KEY	BOTANICAL NAME	COMMON NAME	SPACING
9	CO	CERCIS CANADENSIS VAR. TEXENSIS 'OKLAHOMA'	OKLAHOMA REDBUD	18' O.C.
15	DV	DISTYLIMUM 'VINTAGE JADE'	VINTAGE JADE DISTYLIMUM	4' O.C.; STAGGERED
8	FI	FORSYTHIA X INTERMEDIA 'MINDOR'	SHOWOFF FORSYTHIA	6' O.C.
1395	HO	HEMEROCALLIS 'ORANGE VOLS' [TUSCAWILLA TIGRESS 'ORANGE']	ORANGE VOLS DAYLILY [TUSCAWILLA TIGRESS 'ORANGE']	2' O.C.
3	JB	JUNIPERUS VIRGINIANA 'BURKII'	BURKII EASTERN RED CEDAR	12' O.C.
8	MB	MAGNOLIA GRANDIFLORA 'BRACKEN'S BROWN BEAUTY'	BRACKEN'S BROWN BEAUTY MAGNOLIA	AS SHOWN
127	PN	PANICUM VIRGATUM 'NORTHWIND'	NORTHWIND SWITCHGRASS	3' O.C.

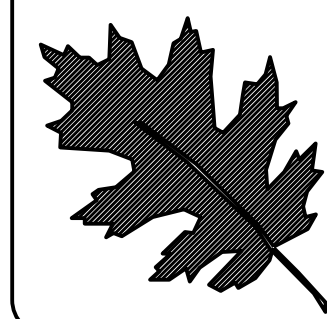

NCDOT - ROADSIDE ENVIRONMENTAL UNIT  
 LANDSCAPE DESIGN & DEVELOPMENT  
 1557 MAIL SERVICE CENTER RALEIGH NC 27699-1557  
 PH: 919-707-2935 FAX: 919-715-2554  
[HTTP://WWW.NCDOT.ORG/DOH/OPERATIONS/DP\\_CHIEF\\_ENG/ROADSIDE/](http://www.ncdot.org/DOH/OPERATIONS/DP_CHIEF_ENG/ROADSIDE/)

I-85 & NC 109 IN THOMASVILLE  
 DAVIDSON COUNTY

WBS #: - - - - -

REV. DESIGNER

SHEET DESCRIPTION:  
 PREL. DESIGN DATE: NOV. 1, 2017  
 CHECKED BY & DATE: - - - - -  
 FINAL DESIGN DATE: - - - - -

QUADRANT A  
 PLANTING PLAN  
 LANDSCAPE PLAN SHEET

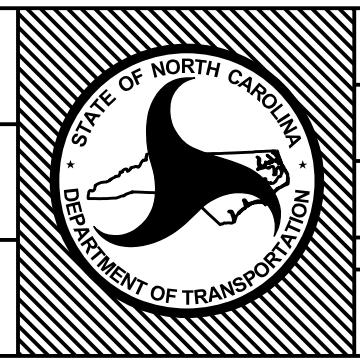

T.I.P. # - - - - -  
 WBS # - - - - -  
 FED I.D. # - - - - -  
 SHEET NO.: **L-5** TOTAL SHEET NO.: **L-10**

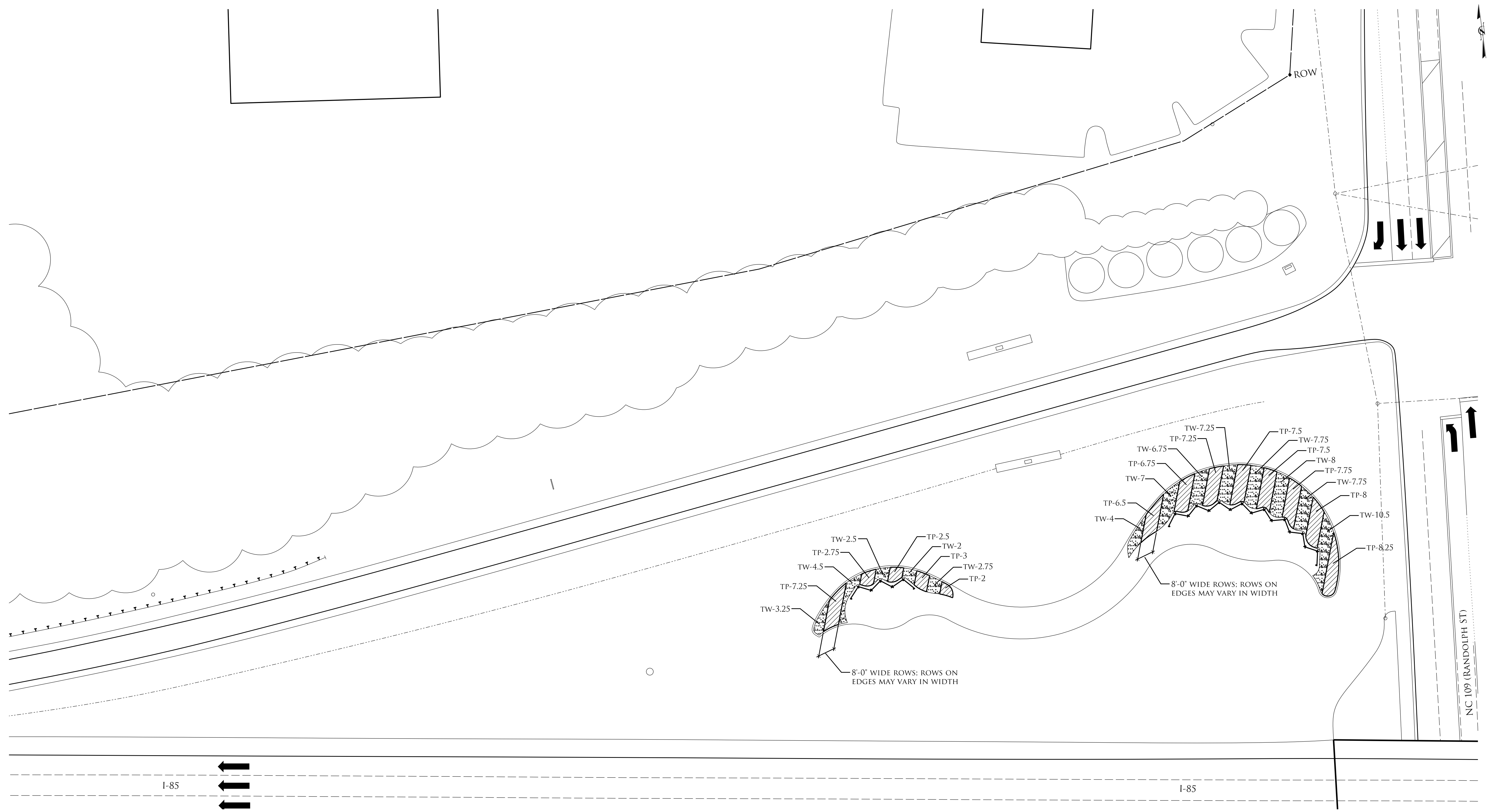

I-85

I-85

NC 109 (RANDOLPH ST)



QTY	KEY	BOTANICAL NAME	COMMON NAME	SPACING
77 PACKS	TP	TULIPA 'PURPLE PRINCE' [NEGrita] (PACK OF 50 BULBS)	PURPLE PRINCE TULIP [NEGrita]	2 BULBS PER SQFT
74 PACKS	TW	TULIPA 'PURISSIMA' [MAUREEN] (PACK OF 50 BULBS)	PURISSIMA TULIP [MAUREEN]	2 BULBS PER SQFT

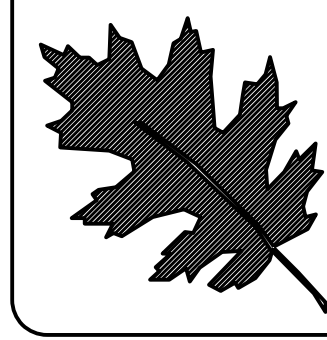

NCDOT - ROADSIDE ENVIRONMENTAL UNIT  
 LANDSCAPE DESIGN & DEVELOPMENT  
 1557 MAIL SERVICE CENTER RALEIGH NC 27699-1557  
 PH: 919-707-2935 FAX: 919-715-2554  
[HTTP://WWW.NCDOT.ORG/DOH/OPERATIONS/DP\\_CHIEF\\_ENG/ROADSIDE/](http://www.ncdot.org/DOH/OPERATIONS/DP_CHIEF_ENG/ROADSIDE/)

I-85 & NC 109 IN THOMASVILLE  
 DAVIDSON COUNTY

WBS #: - - - - -

REV. DESIGNER  
*Kyle Coody*

PREL. DESIGN DATE:	NOV. 1, 2017
CHECKED BY & DATE:	- - - - -
FINAL DESIGN DATE:	- - - - -

QUADRANT A  
 BULB LAYOUT PLAN  
 LANDSCAPE PLAN SHEET

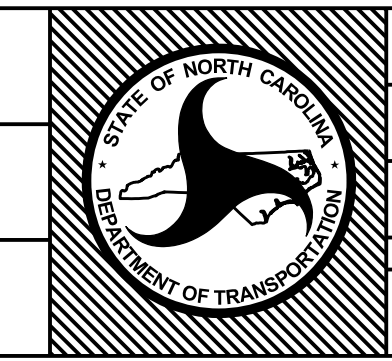

T.I.P. #	- - - - -
WBS #	- - - - -
FED I.D. #	- - - - -
SHEET NO.:	L-6
TOTAL SHEET NO.:	L-10

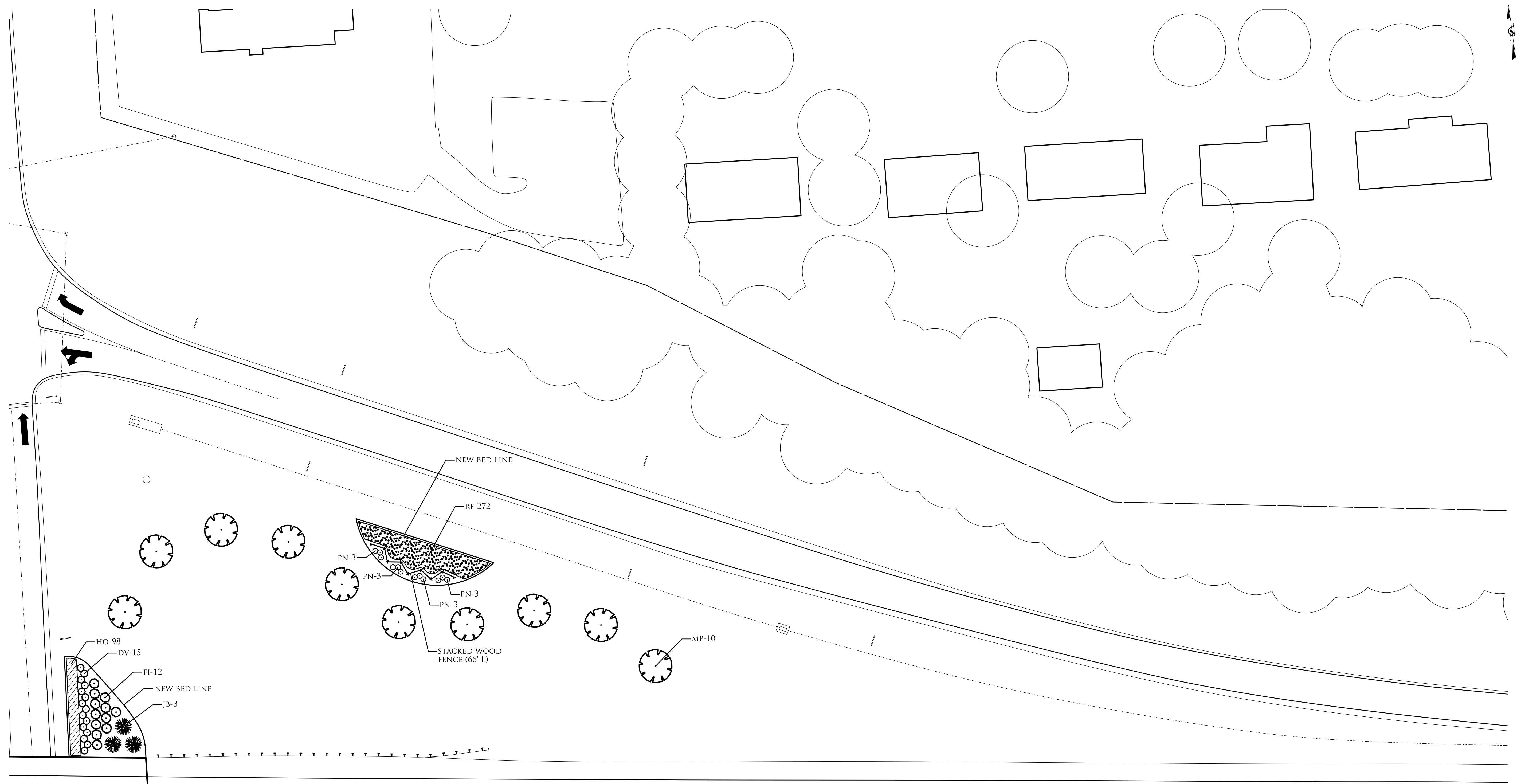

I-85



QTY	KEY	BOTANICAL NAME	COMMON NAME	SPACING
15	DV	<i>DISTYLIUM 'VINTAGE JADE'</i>	VINTAGE JADE DISTYLIUM	4' O.C.; STAGGERED
12	FI	<i>FORSYTHIA X INTERMEDIA 'MINDOR'</i>	SHOWOFF FORSYTHIA	6' O.C.
98	HO	<i>HEMEROCALLIS 'ORANGE VOLS' [TUSCAWILLA TIGRESS: 'ORANGE']</i>	ORANGE VOLS DAYLILY [TUSCAWILLA TIGRESS: ORANGE]	2' O.C.
3	JB	<i>JUNIPERUS VIRGINIANA 'BURKII'</i>	BURKII EASTERN RED CEDAR	12' O.C.
10	MP	<i>MALUS X 'PRAIRIFIRE'</i>	PRAIRIFIRE CRABAPPLE	40' O.C.
12	PN	<i>PANICUM VIRGATUM 'NORTHWIND'</i>	NORTHWIND SWITCHGRASS	3' O.C.
272	RF	<i>RUDBECKIA FULGIDA VAR. SULLIVANTH 'GOLDSTURM'</i>	GOLDSTURM BLACK-EYED SUSAN	2' O.C.

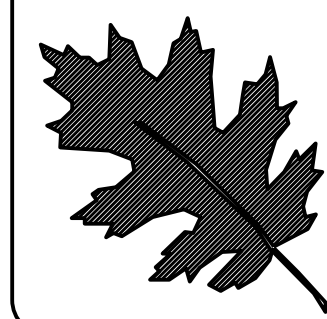

NCDOT - ROADSIDE ENVIRONMENTAL UNIT  
 LANDSCAPE DESIGN & DEVELOPMENT  
 1557 MAIL SERVICE CENTER RALEIGH NC 27699-1557  
 PH: 919-707-2935 FAX: 919-715-2554  
[HTTP://WWW.NCDOT.ORG/DOH/OPERATIONS/DP\\_CHIEF\\_ENG/ROADSIDE/](http://www.ncdot.org/DOH/OPERATIONS/DP_CHIEF_ENG/ROADSIDE/)

I-85 & NC 109 IN THOMASVILLE  
 DAVIDSON COUNTY

WBS #: - - - - -

REV. DESIGNER  
*Kyle Corder*

SHEET DESCRIPTION:  
 PREL. DESIGN DATE: Nov. 1, 2017  
 CHECKED BY & DATE: - - - - -  
 FINAL DESIGN DATE: - - - - -

QUADRANT B  
 PLANTING PLAN  
 LANDSCAPE PLAN SHEET

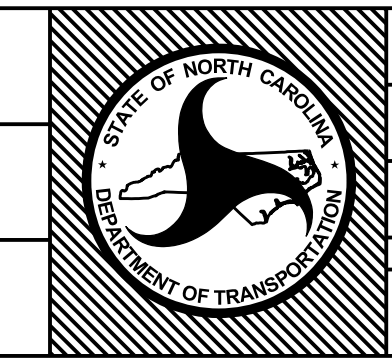

T.I.P. # - - - - -  
 WBS # - - - - -  
 FED I.D. # - - - - -  
 SHEET NO.: **L-7** TOTAL SHEET NO.: **L-10**

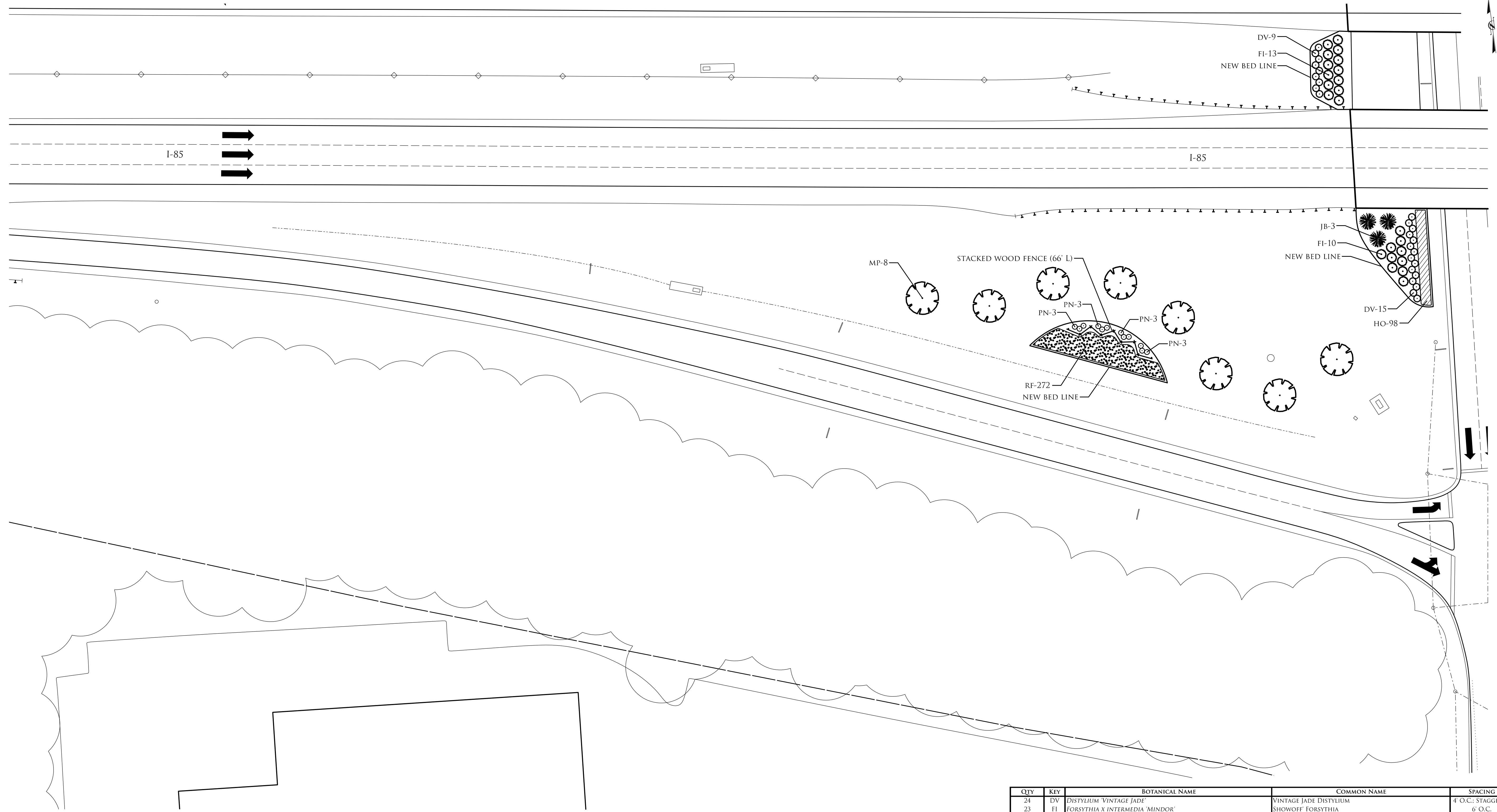

QTY	KEY	BOTANICAL NAME	COMMON NAME	SPACING
24	DV	<i>DISTYLIMUM 'VINTAGE JADE'</i>	VINTAGE JADE DISTYLIMUM	4' O.C.; STAGGERED
23	FI	<i>FORSYTHIA X INTERMEDIA 'MINDOR'</i>	SHOWOFF FORSYTHIA	6' O.C.
98	HO	<i>HEMEROCALLIS 'ORANGE VOLS' [TUSCAWILLA TIGRESS: 'ORANGE']</i>	ORANGE VOLS DAYLILY [TUSCAWILLA TIGRESS: ORANGE]	2' O.C.
3	JB	<i>JUNIPERUS VIRGINIANA 'BURKII'</i>	BURKII EASTERN RED CEDAR	12' O.C.
8	MP	<i>MALUS X 'PRAIRIFIRE'</i>	PRAIRIFIRE CRABAPPLE	40' O.C.
12	PN	<i>PANICUM VIRGATUM 'NORTHWIND'</i>	NORTHWIND SWITCHGRASS	3' O.C.
272	RF	<i>RUDBECKIA FULGIDA VAR. SULLIVANTII 'GOLDSTURM'</i>	GOLDSTURM BLACK-EYED SUSAN	2' O.C.

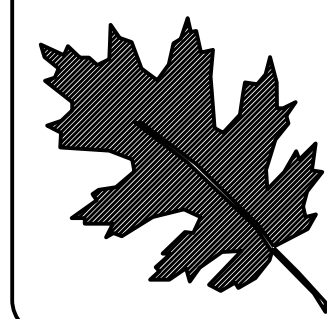

NCDOT - ROADSIDE ENVIRONMENTAL UNIT  
 LANDSCAPE DESIGN & DEVELOPMENT  
 1557 MAIL SERVICE CENTER RALEIGH NC 27699-1557  
 PH: 919-707-2935 FAX: 919-715-2554  
[HTTP://WWW.NCDOT.ORG/DOH/OPERATIONS/DP\\_CHIEF\\_ENG/ROADSIDE/](http://www.ncdot.org/DOH/OPERATIONS/DP_CHIEF_ENG/ROADSIDE/)

I-85 & NC 109 IN THOMASVILLE  
 DAVIDSON COUNTY

WBS #: - - - - -

REV. DESIGNER  
*Kyle Corder*

PREL. DESIGN DATE:	NOV. 1, 2017
CHECKED BY & DATE:	- - - - -
FINAL DESIGN DATE:	- - - - -

QUADRANT C  
 PLANTING PLAN  
 LANDSCAPE PLAN SHEET

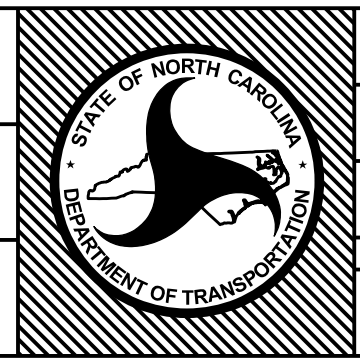

T.I.P. #	- - - - -
WBS #	- - - - -
FED I.D. #	- - - - -
SHEET NO.:	L-8
TOTAL SHEET NO.:	L-10



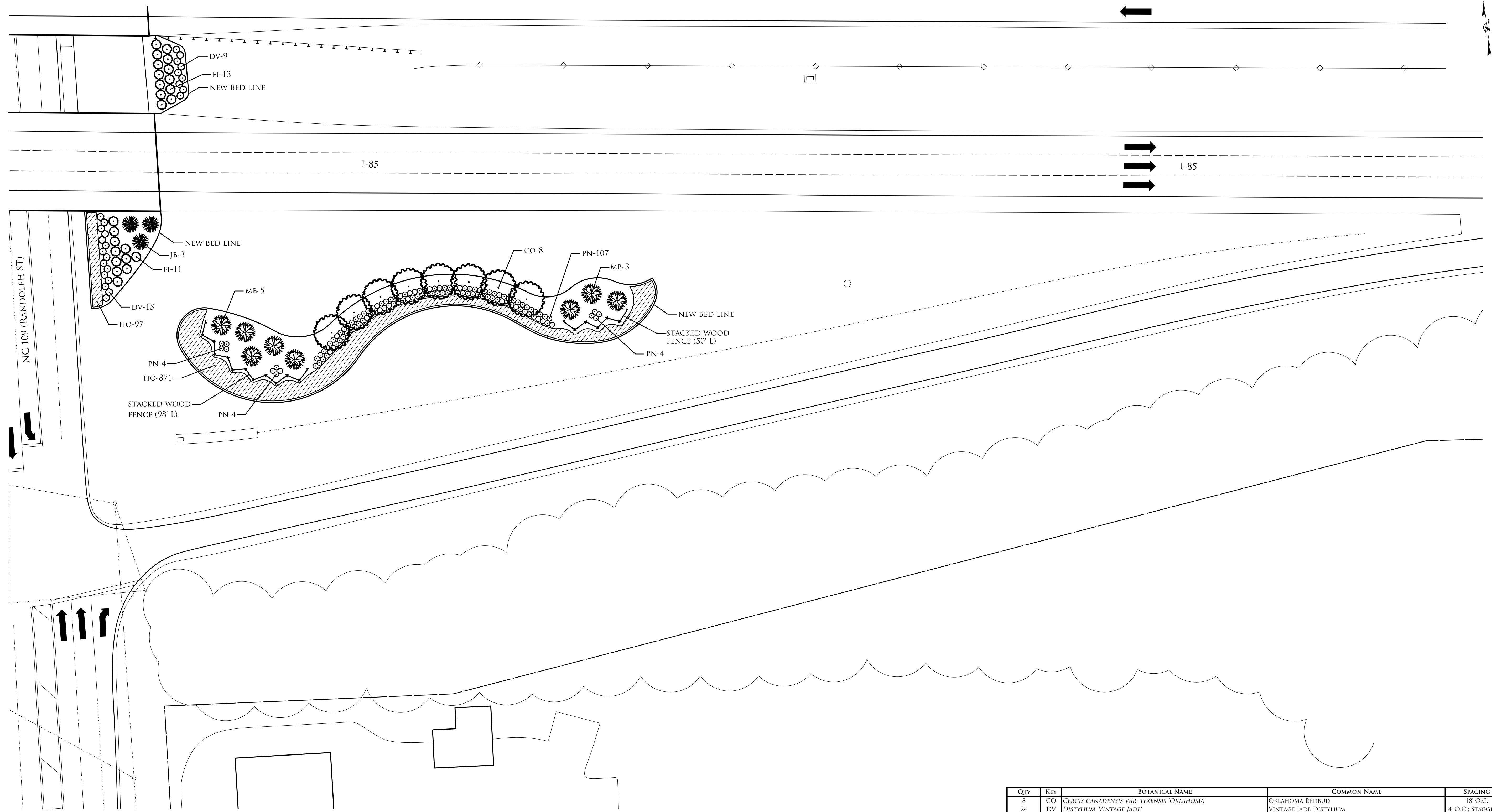

QTY	KEY	BOTANICAL NAME	COMMON NAME	SPACING
8	CO	CERCIS CANADENSIS VAR. TEXENSIS 'OKLAHOMA'	OKLAHOMA REDBUD	18' O.C.
24	DV	DISTYLIIUM VINTAGE JADE'	VINTAGE JADE DISTYLIIUM	4' O.C.; STAGGERED
24	FI	FORSYTHIA X INTERMEDIA 'MINDOR'	SHOWOFF FORSYTHIA	6' O.C.
968	HO	HEMEROCALLIS 'ORANGE VOLS' [TUSCAWILLA TIGRESS: 'ORANGE']	ORANGE VOLS DAYLILY [TUSCAWILLA TIGRESS: 'ORANGE']	2' O.C.
3	JB	JUNIPERUS VIRGINIANA 'BURKII'	BURKII EASTERN RED CEDAR	12' O.C.
8	MB	MAGNOLIA GRANDIFLORA 'BRACKEN'S BROWN BEAUTY'	BRACKEN'S BROWN BEAUTY MAGNOLIA	AS SHOWN
119	PN	PANICUM VIRGATUM 'NORTHWIND'	NORTHWIND SWITCHGRASS	3' O.C.

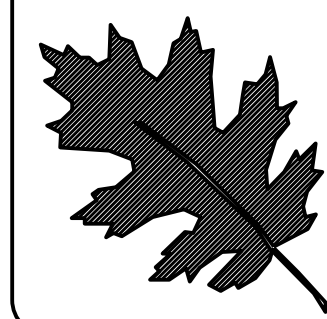

NCDOT - ROADSIDE ENVIRONMENTAL UNIT  
 LANDSCAPE DESIGN & DEVELOPMENT  
 1557 MAIL SERVICE CENTER RALEIGH NC 27699-1557  
 PH: 919-707-2935 FAX: 919-715-2554  
[HTTP://WWW.NCDOT.ORG/DOH/OPERATIONS/DP\\_CHIEF\\_ENG/ROADSIDE/](http://www.ncdot.org/DOH/OPERATIONS/DP_CHIEF_ENG/ROADSIDE/)

I-85 & NC 109 IN THOMASVILLE  
 DAVIDSON COUNTY

WBS #: - - - - -

REV. DESIGNER  
*Kyle Corder*

PREL. DESIGN DATE:	Nov. 1, 2017
CHECKED BY & DATE:	- - - - -
FINAL DESIGN DATE:	- - - - -

QUADRANT D  
 PLANTING PLAN  
 LANDSCAPE PLAN SHEET

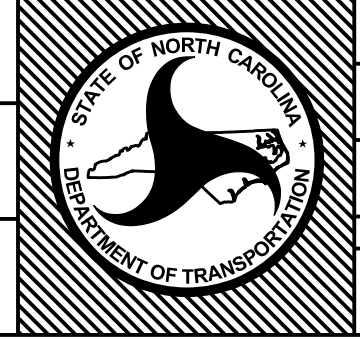

T.I.P. #	- - - - -
WBS #	- - - - -
FED I.D. #	- - - - -
SHEET NO.:	L-9
TOTAL SHEET NO.:	L-10

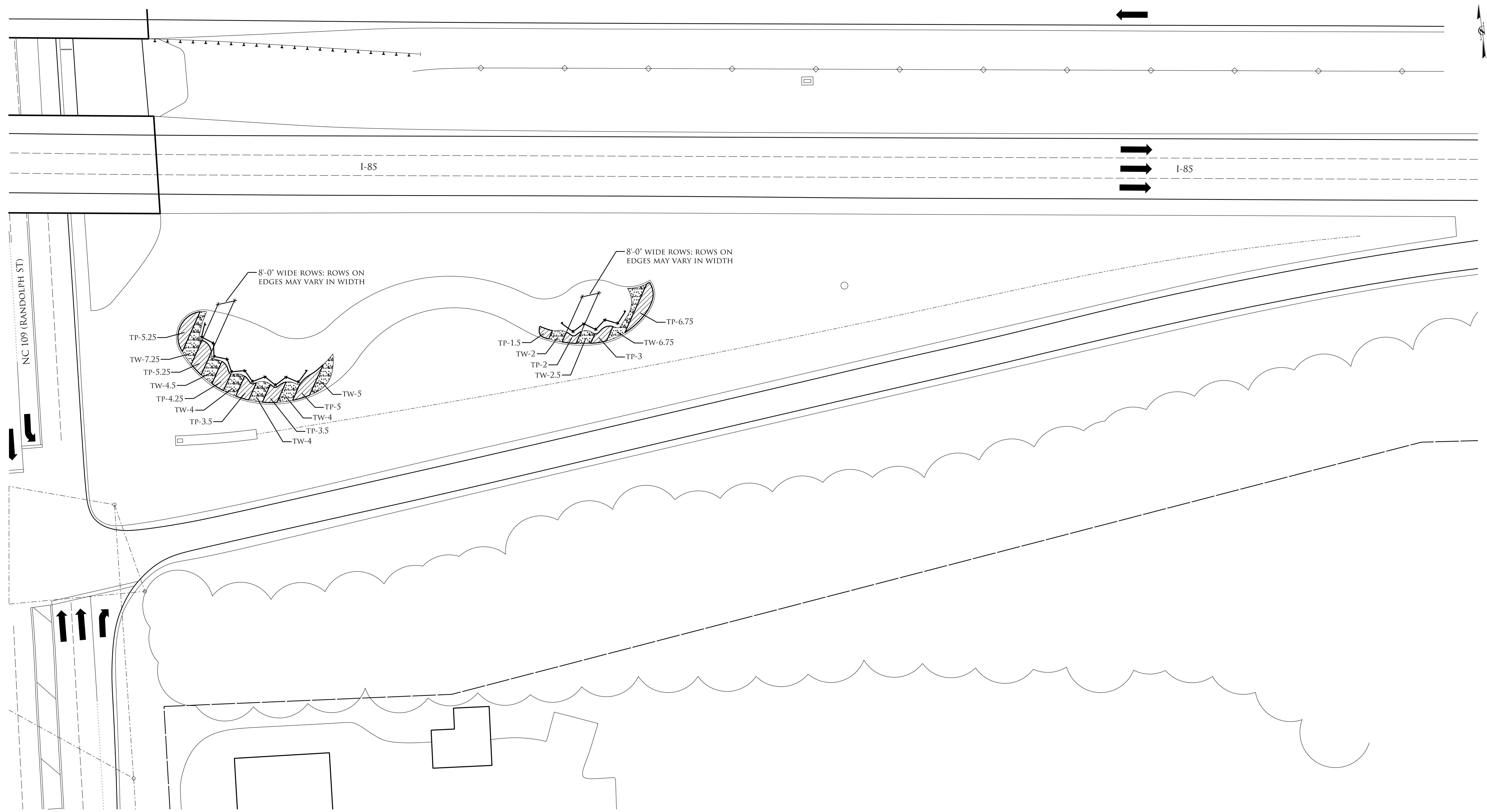

NC 109 (RANDOLPH ST)

I-85

I-85

8'-0" WIDE ROWS; ROWS ON EDGES MAY VARY IN WIDTH

8'-0" WIDE ROWS; ROWS ON EDGES MAY VARY IN WIDTH



QTY	KEY	BOTANICAL NAME	COMMON NAME	SPACING
40 PACKS	TP	TULIPA 'PURPLE PRINCE' [NEGRITA] (PACK OF 50 BULBS)	PURPLE PRINCE TULIP [NEGRITA]	2 BULBS PER SQFT
40 PACKS	TW	TULIPA 'PURISSIMA' [MAUREEN] (PACK OF 50 BULBS)	PURISSIMA TULIP [MAUREEN]	2 BULBS PER SQFT

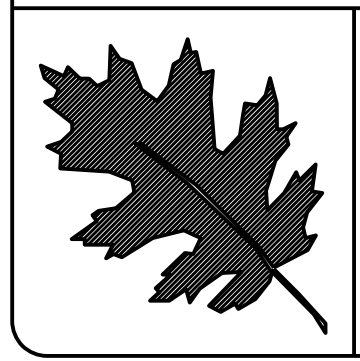

NCDOT - ROADSIDE ENVIRONMENTAL UNIT  
 LANDSCAPE DESIGN & DEVELOPMENT  
 1557 MAIL SERVICE CENTER RALEIGH NC 27699-1557  
 PH: 919-707-2935 FAX: 919-715-2554  
[HTTP://WWW.NCDOT.ORG/DOH/OPERATIONS/DP\\_CHIEF\\_ENG/ROADSIDE/](http://www.ncdot.org/DOH/OPERATIONS/DP_CHIEF_ENG/ROADSIDE/)

I-85 & NC 109 IN THOMASVILLE  
 DAVIDSON COUNTY  
 WBS #: - - - - -

REV. DESIGNER  
*Kyle Corder*

PREL. DESIGN DATE:	Nov. 1, 2017
CHECKED BY & DATE:	- - - - -
FINAL DESIGN DATE:	- - - - -

QUADRANT D  
 BULB LAYOUT PLAN  
 LANDSCAPE PLAN SHEET

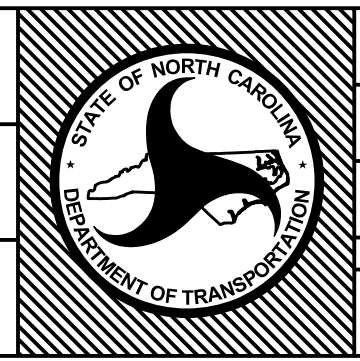

T.I.P. #	- - - - -
WBS #	- - - - -
FED I.D. #	- - - - -
SHEET NO.:	L-10
TOTAL SHEET NO.:	L-10